

PRESIDIO® Reliant® Guardrail Series

Guardrail Kit Instructions

TOOLS REQUIRED: Tape Measure - Screw Gun - Screw/Drill Bit
Chop Saw/Hack Saw - Square - Level

GUARDRAIL KIT CONTENTS

Components	4' Kit	6' Kit	8' Kit
Top Rail - 2" x 3-1/2" Hollow with pre-routed holes (Top rail routed on one side of rail)	(1)	(1)	(1)
Bottom Rail - 2" x 3-1/2" Webbed with pre-routed holes (Bottom rail routed on both sides of rail)	(1)	(1)	(1)
Aluminum Insert - for top rail	(1)	(1)	(1)
2" x 3-1/2" Guardrail Brackets - with nylon post brackets, covers and fasteners	(4)	(4)	(4)
Balusters - 1-1/2" Square or 1-1/2" Colonial (one style per selected kit)	(9)	(14)	(18)
Foot Block - notched on one end	(1)	(1)	(1)

*Accessories items may be purchased separately.

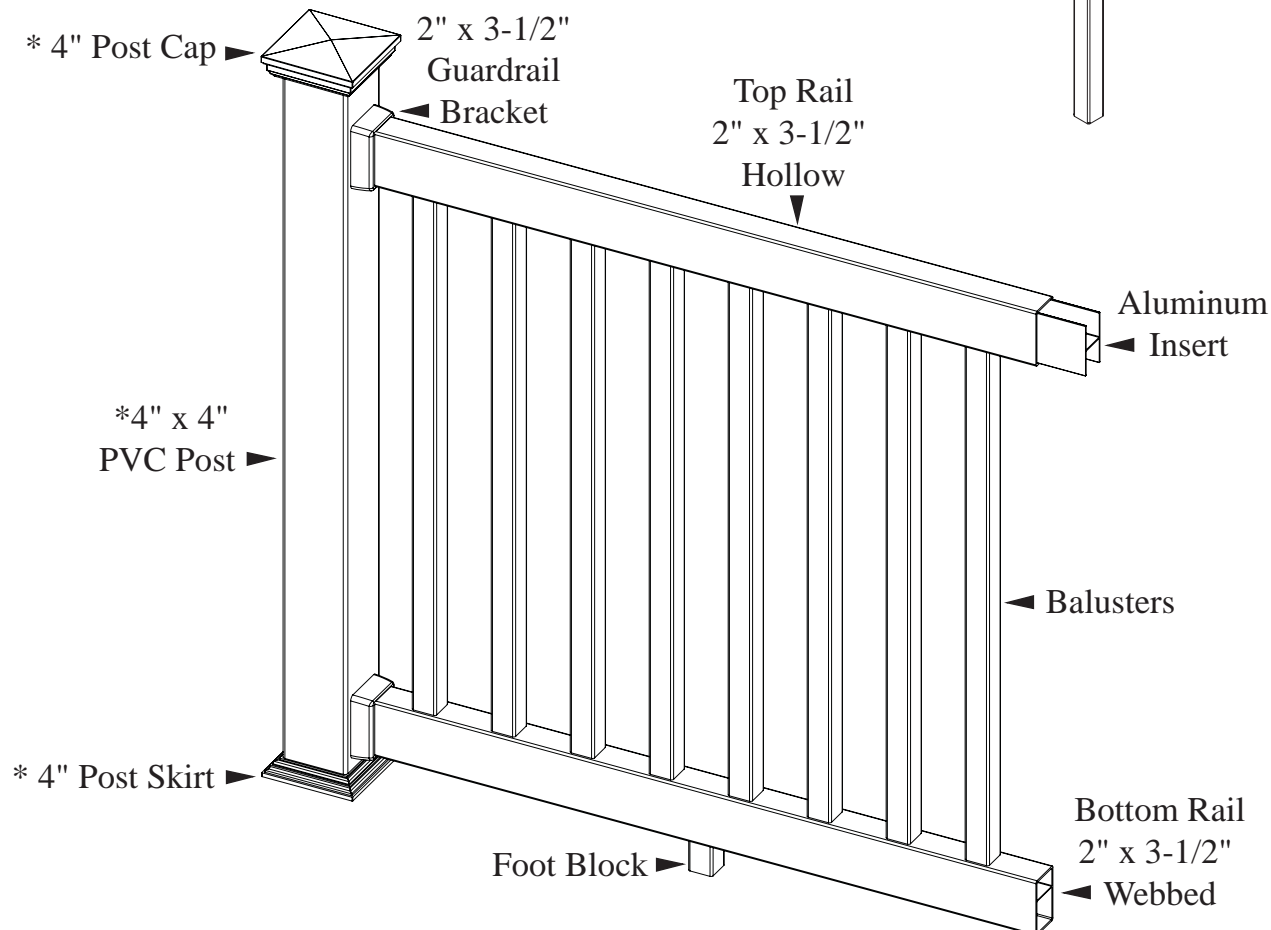
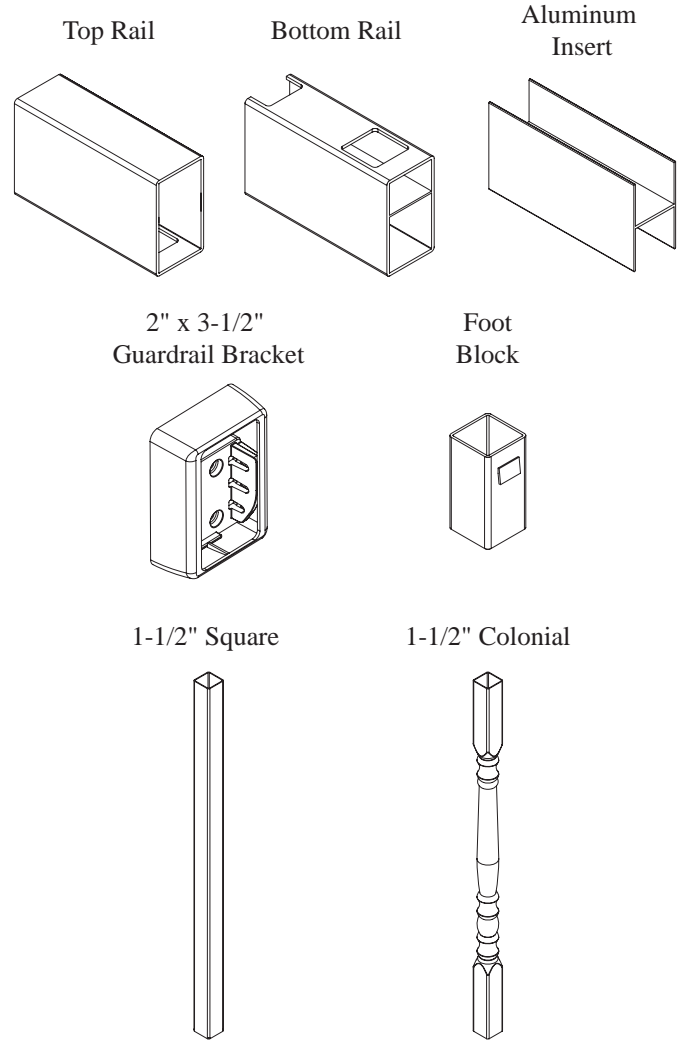

Reliant® Guardrail Series Assembly Instructions

Step 1 - Prepare and install posts and decking. Prepare the posts and mounting surfaces to which the rail section will be attached. A typical installation uses a 4" x 4" vinyl post sleeved over either a 4" x 4" treated wood post, or an LMT Blu-Mount with aluminum or PVC guides. When using PRESIDIO® PVC Decking, the 4" x 4" treated wood post should extend 38-1/2" above the wood joist framed structure for 36" high railing systems, and 44-1/2" above the wood joist framed structure for 42" high railing systems. Cut and fasten the posts to the wood framing or if you are installing your PRESIDIO® guardrail system on a concrete surface, install LMT Blu Mounts following the supplied Blu Mount installation instructions. Install decking boards over or around post supports. (Please refer to the decking installation instruction manual for the correct installation procedures of the deck boards.) Sleeve the post supports with a 4" vinyl post. (This sleeve should measure 38" above the finished deck surface for 36" railing heights or 44" for 42" railing heights.) The installed post sleeves must be plumb for correct installation of the rail section. If vinyl post skirts are being used at the base of the posts, slide the post skirts into position so that they come to rest around the base of the 4" x 4" sleeved post.

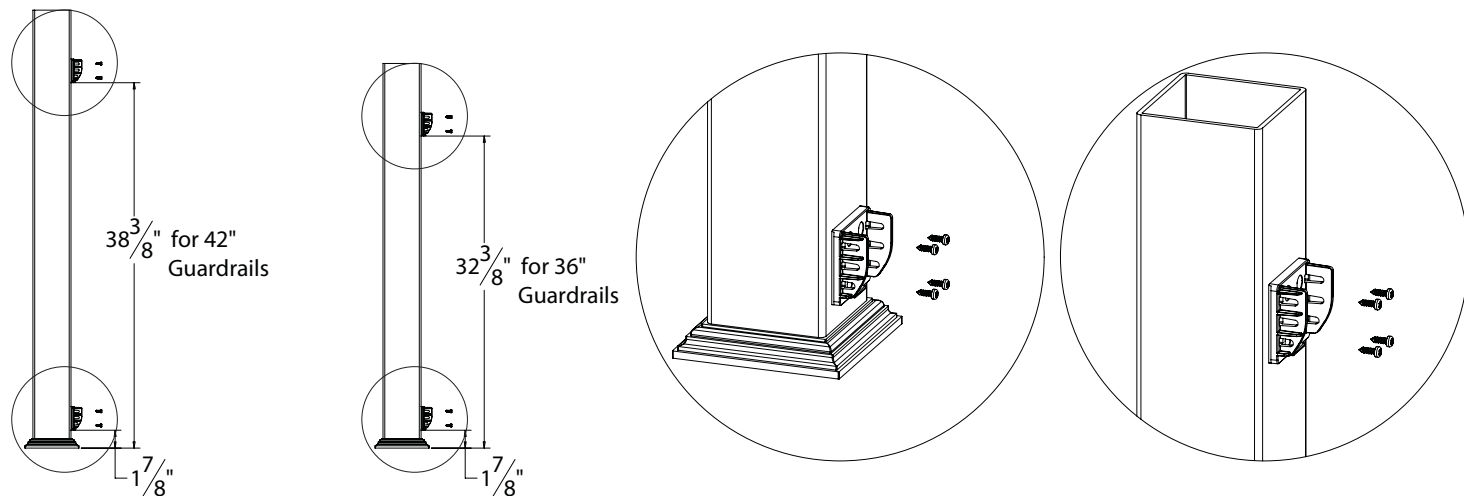

Step 2 - Secure post mounting brackets. Attach the nylon post brackets to the sleeved posts by using the (4) #10 x 1-1/2" pan-head screws for the 4" x 4" treated wood post, or the (4) #10 x 1" pan-head screws for the LMT Blu-Mount with aluminum or PVC guides. Measure and secure the bottom nylon post bracket 1-7/8" from the installed deck surface. Similarly secure the top nylon post brackets to the installed posts 38-3/8" from the deck surface for a 42" railing heights or 32-3/8" for 36" railing heights.

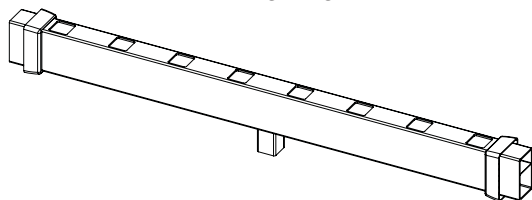

Step 3 - Measure and cut the bottom rail. The bottom rail is identified by having routed holes on each side of the rail. One side for the insertion of the balusters and the other for the foot block. Measure the distance between the base plates of opposing nylon post brackets. If cutting of the bottom rail is necessary, cut an equal amount off both ends of the rail so to maintain uniform baluster spacing between the posts. Insert the foot block into the bottom of rail so the notched end of the picket is inside the rail. Loosely position the 2" x 3-1/2" bracket covers on opposing ends of the bottom rail.

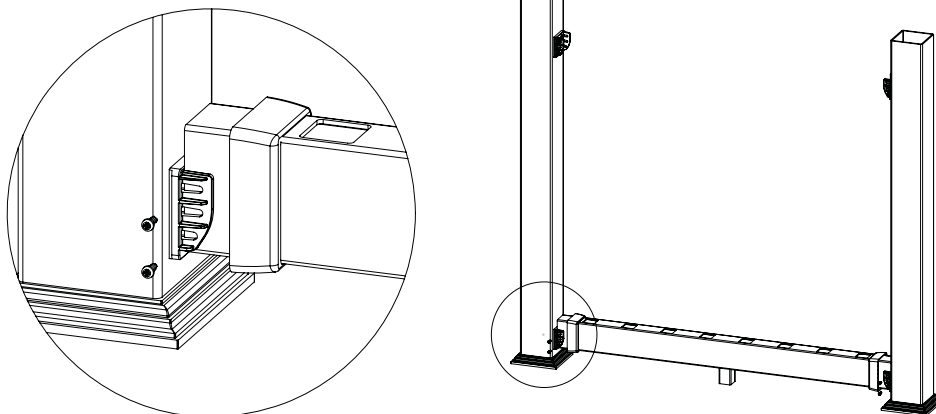

Step 4 - Secure the bottom rail. Attach the bottom rail to the nylon post brackets by using the (4) #10 x 1" pan-head screws. The bottom rail will be 2" off the deck surface with the foot block resting on the deck surface and the rail inserted correctly into the nylon post brackets. Fasten two screws into each side of the nylon post bracket using the top and bottom slots of the nylon post brackets. Once secured, snap the 2" x 3-1/2" straight bracket covers positioned in Step 3 onto the nylon post brackets.

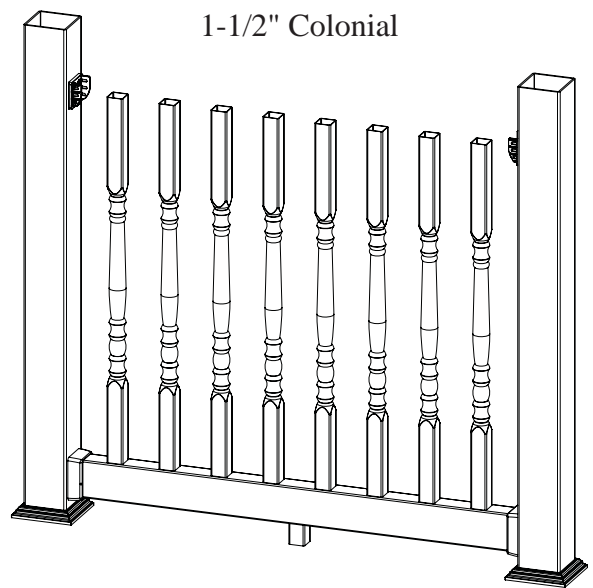
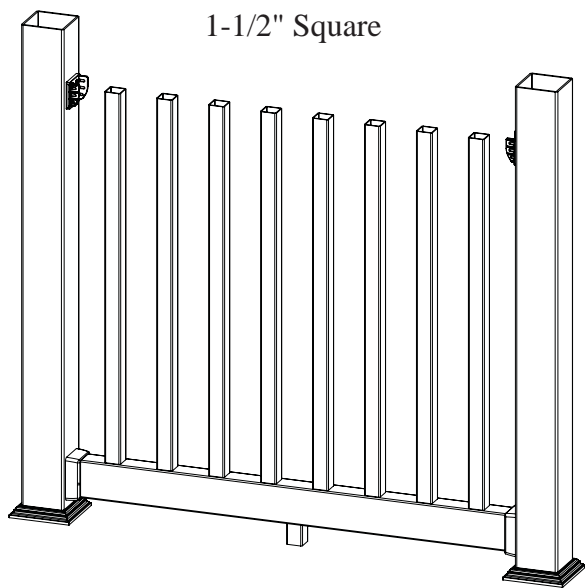

Step 5 - Insert the balusters. Having secured the bottom rail into place, insert the balusters into the bottom rail. If the 1-1/2" colonial balusters are being used make sure the balusters are inserted so the baluster tapers are uniformly installed.

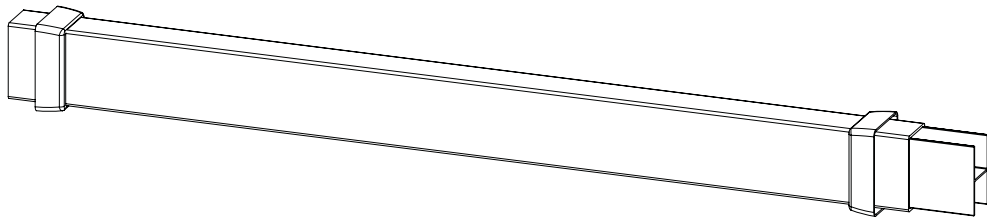

Step 6 - Measure and cut the top rail. If cutting of the top rail is necessary cut an equal amount off both ends of the rail to maintain a uniform baluster spacing between the posts. The rail kits are provided with an aluminum insert and must be used. Cut the aluminum insert to the appropriate length of the measured top rail. Insert the aluminum into the top rail and loosely position the 2" x 3-1/2" bracket covers on opposing ends of the top rail.

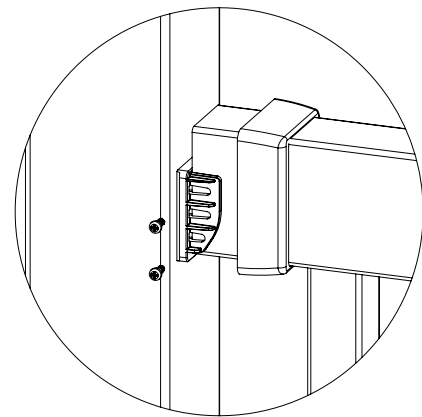
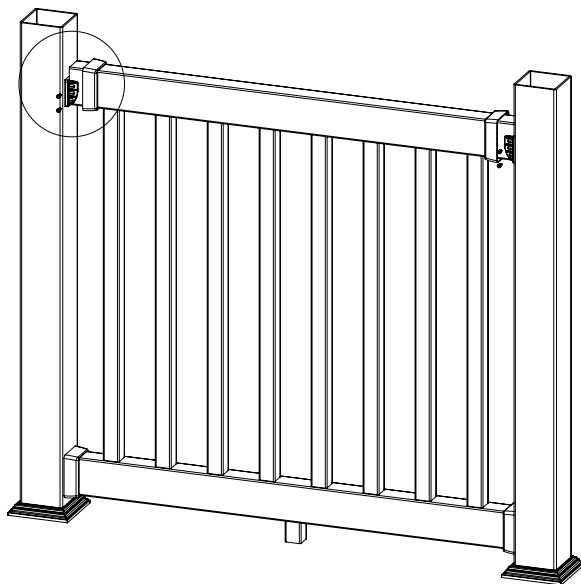

Step 7 - Secure the top rail. Position the top rail over the exposed ends of the balusters so that it is positioned on the resting flange of the installed nylon post brackets. Attach the top rail to the nylon post brackets by using the (4) #10 x 1" pan-head screws. Fasten two screws into each side of the nylon post bracket using the top and bottom slots of the nylon post brackets. Snap the 2" x 3-1/2" bracket covers positioned in Step 6 onto the nylon post brackets.

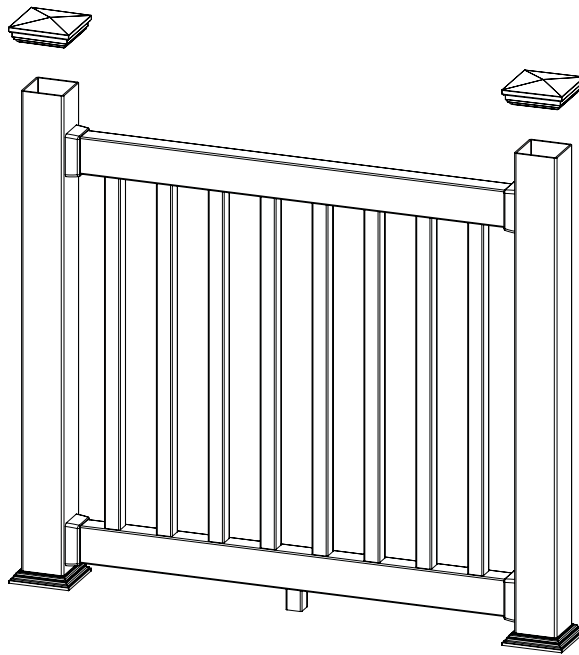

Step 8 - Finish the section. Secure the 4" x 4" post caps onto the post tops by applying PVC adhesive to the internal surfaces of the post caps. Set the caps onto the post tops. Wipe off any excess adhesive.

Please direct product inquiries to:

Customer Service Department

Westech Building Products

P.O. Box 567

Mount Vernon, IN 47620

U.S.A

Tel. (812) 985-3628

Fax. (812) 985-2925

info@westechbp.com